

INSTRUCTION MANUAL

ST- SAFETY COUPLINGS

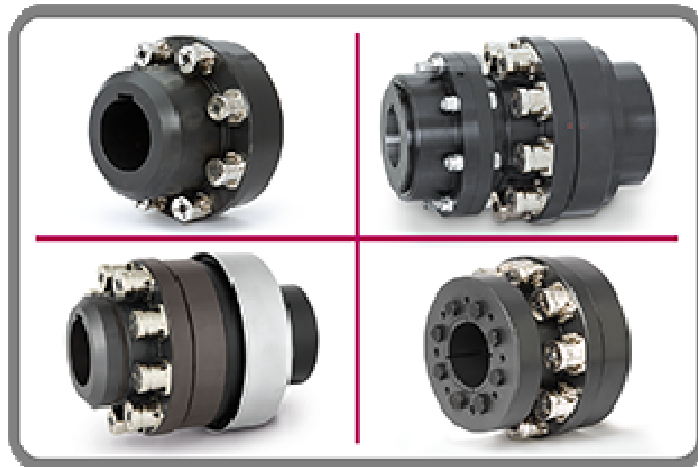

Document ID: RW Manual – ST / Rev. 17.12

R+W ANTRIEBSELEMENTE GMBH

HATTSTEINSTRASSE 4
D-63939 WÖRTH AM MAIN
WWW.RW-KUPPLUNGEN.DE

PHONE: +49 9372 9864-0
FAX: +49 9372 9864-20
INFO@RW-KUPPLUNGEN.DE



QUALITY MANAGEMENT
We are certified !

according to ISO 9001:2008

D-ZM-16029-01-01 Registration No. 40503432/3

The information included in this document is based on our present knowledge and experience and does not exclude the manufacturer's own substantial testing of the products. Therefore we do not guarantee protection against third party claims. The sale of our product is in accordance with our general terms and conditions.

INSTRUCTION MANUAL

ST SAFETY COUPLINGS



ST / Rev. 17.12

- ST1
- STN
- STF
- ST2
- STE
- ST3
- ST4
- STB
- ST-R

I. DESIGN & COMPOSITION ex factory R+W

R+W Safety Couplings from the Standard Series integrates robust Bearings, built in with the preload perfectly matched to each coupling at final assembly .
The ST Series are sealed in order to avoid intrusion of dust or other substances as well as preventing the leakage of grease.

R+W Safety Elements, Type ST consist of two main parts:
Part 1: detent segment,
Part 2: self-contained, spring loaded plunger module.

The safety elements are equipped with a robust housing which contains the spring loaded plunger assembly.
After adjustment and burn-in procedure of each safety element they are assembled to the safety couplings without any back lash.

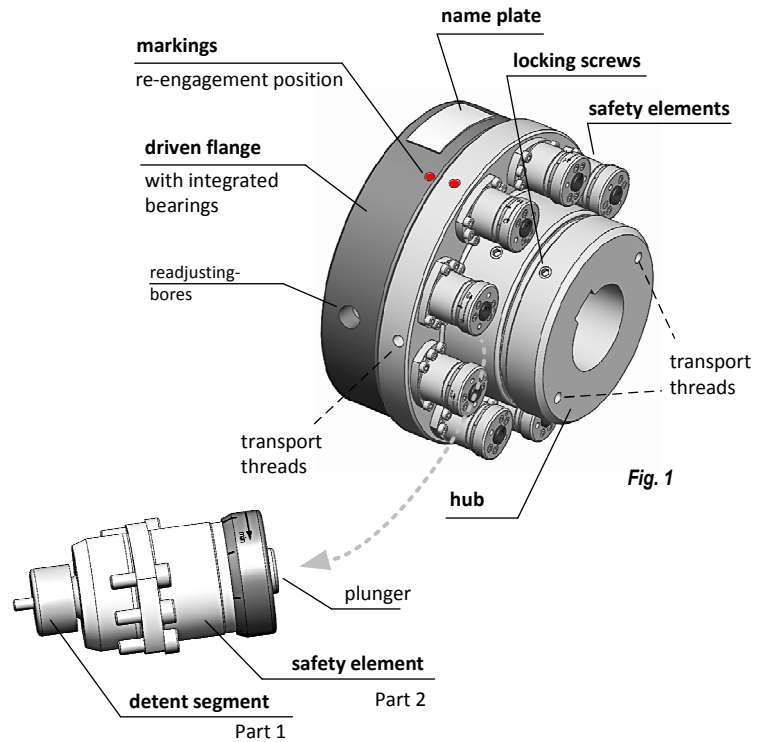

II. TORQUE ADJUSTMENT :

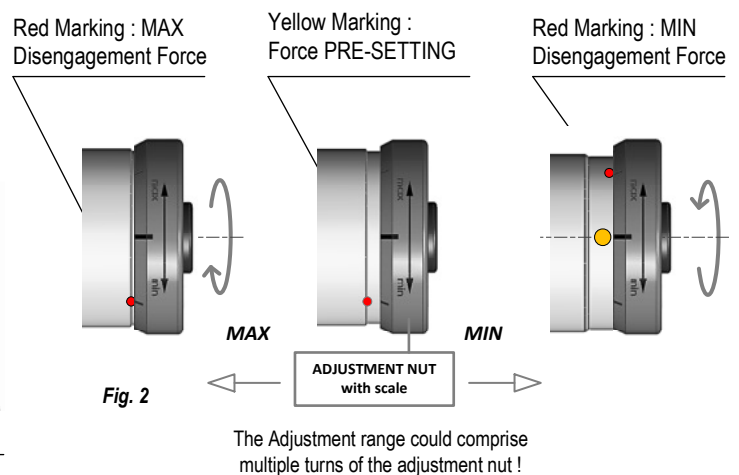
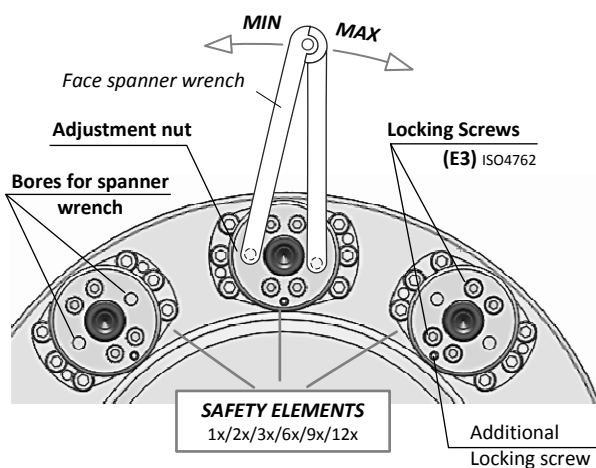

After loosening (approx. 1 rotation) the locking screws (E3), the adjustment nut can be turned to adjust the disengagement setting. Incremental values are marked on the adjustment scale.

After adjustment, the torque setting is secured by tightening the locking screws (E3).

CAUTION

All safety elements must be set To the same value.

INSTRUCTION MANUAL

ST SAFETY COUPLINGS



ST / Rev. 17.12

- ST1
- STN
- STF
- ST2
- STE
- ST3
- ST4
- STB
- ST-R

III. RE-ENGAGEMENT : COUPLING / SAFETY ELEMENTS

After the overload has been cleared, the drive or driven side must be rotated until the re-engagement position markings are lined up. The elements can only be re-engaged in this position. The element is re-engaged through Applying an axial force to the plunger.

Re-engagement is audible. Once this is completed, the torque limiter is ready for operation.

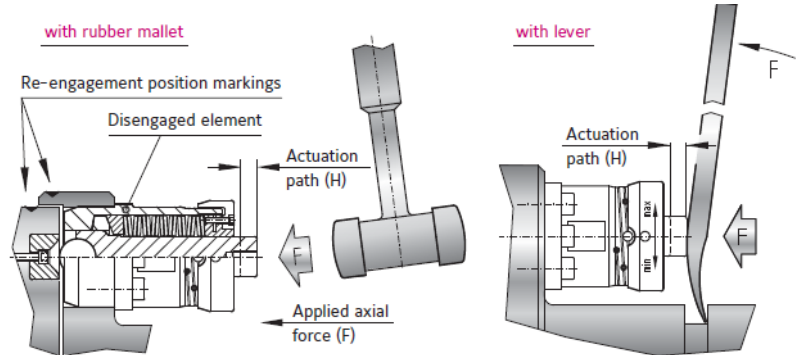

Fig. 3

safety elements SERIES	10/11	15/16	30/31	70/71
Actuation max. H (mm)	3,5	4,5	7,5	10,5
restoring force max. F (kN)	0,4	2	4	6

Tab. 1

IV. DIS-ENGAGEMENT : COUPLING / SAFETY ELEMENTS

Before starting operation, if necessary, the coupling may be disengaged in situ. (see figure 4)

For that R+W offers special tools for all sizes of safety elements.

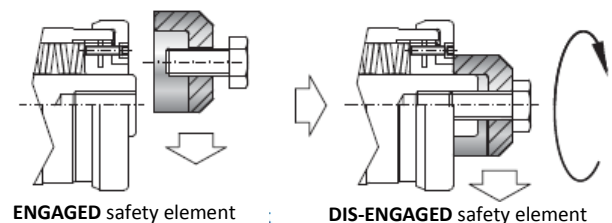

Fig. 4

V. MARKING / NAME PLATE : SAFETY ELEMENTS

Each safety element has a marking engraved on the housing with the following information:

Series of safety element,
Packaging range of springs, serial number
Pre-adjusted re-engagement force in kN.

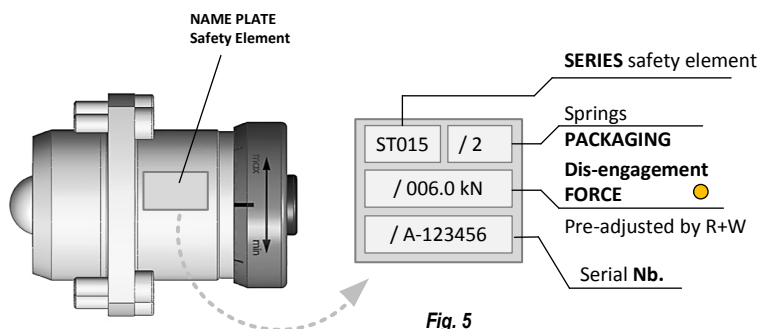

Fig. 5

INSTRUCTION MANUAL

ST SAFETY COUPLINGS



ST / Rev. 17.12

- ST1
- STN
- STF
- ST2
- STE
- ST3
- ST4
- STB
- ST-R

VI. MOUNTING & DIS-MOUNTING : SAFETY ELEMENTS

After loosening the screws (E1) the safety elements the safety elements can be removed from the main body (see Fig.6). To ease removal you find two threaded push-off bores at flange of the safety element's housing .

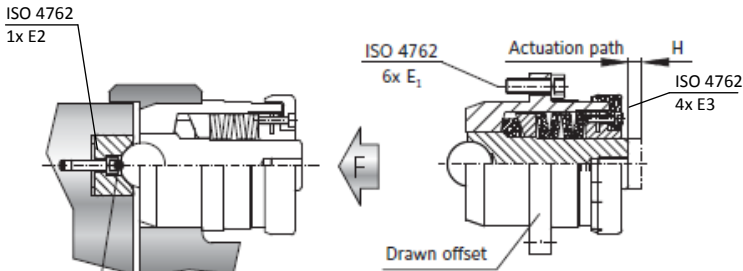

Fig. 6

Note: Prior to mounting the safety element, the ball seat must be lubricated (e.g. Klüber Isoflex Topas NB 52).

SERIES		10/11	15/16	30/31	70/71
Screws (12.9)	E1	6xM4x12	6xM5x16	6xM8x25	6xM12x35
Tightening torque	(Nm)	4.5	10	40	40
Screws (12.9)	E2	1xM3x12	1xM4x12	1xM6x20	1xM8x25
Tightening torque	(Nm)	2	4.5	15.5	38
Screws (12.9)	E3	4xM3x12	4xM4x14	4xM4x16	4xM5x20
Tightening torque	(Nm)	2	4.5	4.5	10
Thread	E4	M4	M5	M8	M10
Actuation path	H (mm)	3.5	4.5	8	10.5
Fit length	L1 (± 0,1 mm)	30/36	36/45	60/69	79/94
Depth measurement	L2 (± 0,1 mm)	7.5/13.5	10/19	20.5/29.5	29/44
Gauge ball	∅ G (mm)	12	16	25	30

Tab. 2

VII. MOUNTING & DIS-MOUNTING : DETENT SEGMENTS

After removing the mounting screws (E2) extract the detent segment using a puller tool. (see Fig.7)

(Fig.8) shows the steps for mounting the detent segment Before re-mounting the safety elements make sure that the Detents are sufficiently greased.

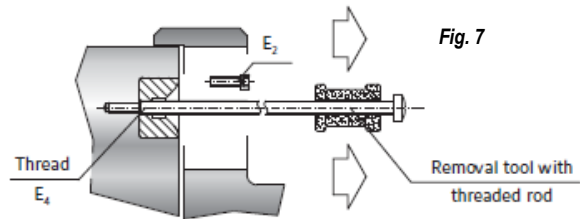

Fig. 7

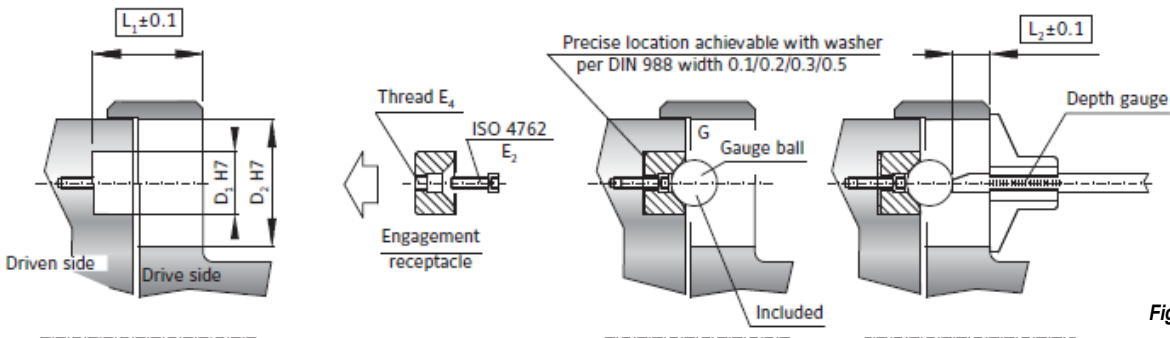

Fig. 8

CAUTION

Dimensions L1 oder L2 (see Tab.2) must be checked before installing the detent segments.

INSTRUCTION MANUAL

ST SAFETY COUPLINGS



ST / Rev. 17.12

ST1 STN STF ST2 STE ST3 ST4 STB ST-R

VIII. INSPECTIONS & MAINTENANCE :

!► After 20 disengagements the coupling should be checked for axial and radial play.

To perform this check, the safety elements need to be disengaged, so that the driven flange can be rotated relative to the main body. (see Fig.9)

Using dial gauges with a resolution of 0.01mm, the axial and radial play can be determined. Depending on the coupling size, normal measurements shall be in the range of 0.03-0.1mm.

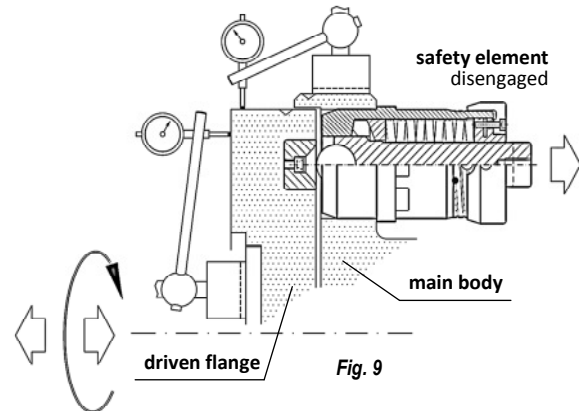

!► Check the detent segments for excessive wear.

Verify dimension L2 using the method shown in Fig.10! It directly effects the clearance between main body and driven flange ! If signs of wear on the detent segments are detected, they must be replaced.

!► Bearing lubrication

Under normal conditions it is not necessary to add grease to the bearings, as they have been designed And assembled for lifetime lubrication.

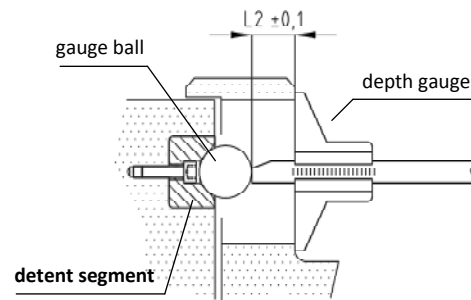

Fig. 10

! CAUTION

In applications which will expose the coupling to heavy vibration, solid waste or dust and dirt, or abrasive liquids, the above mentioned values can change.

Please contact R+W in these cases !

!► NOTE

At the first start up of the safety coupling (particularly sizes 2, 4, 5) it can happen that some grease (from the assembly process) will be blown out. This is normal and will stop after a short running-in time of the coupling. Excessive grease can be removed using a usual Cleaning agent (e.g. Loctite SF 7063).

INSTRUCTION MANUAL

ST SAFETY COUPLINGS



ST / Rev. 17.12

ST2



A1.0 ELASTOMER SEGMENTS – ST2 Series :

Type	Relative damping (ψ)	Temperature range constant	Temperature range peak	Material	Shore hardness	Features
A (Standard)	1.0	-40°C to +80°C	+90°C	Natural and synthetic rubber	75-80 Shore A	Very high wear resistance
B	1.0	-40°C to +100°C	+120°C	Synthetic rubber	73-78 Shore A	Resistant to many oils and fuels
C	1.0	-70°C to +120°C	+140°C	Silicone rubber	70-75 Shore A	High temperature range

Tab. A1

The compensating elements of the ST2 safety couplings are the elastomer segments. They transmit torque while damping vibration and compensating for lateral, axial and Angular misalignment. Three different versions are available with version A being supplied with the ST2 safety coupling unless otherwise specified.

Elastomer segments can be easily changed after installation. Every coupling utilizes 6x elastomer segments. The elastomer segments do not need to be installed prior to coupling mounting.

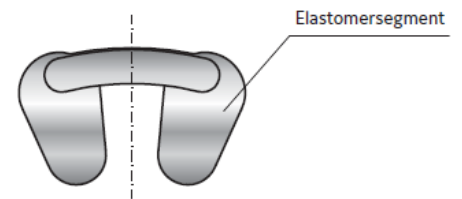
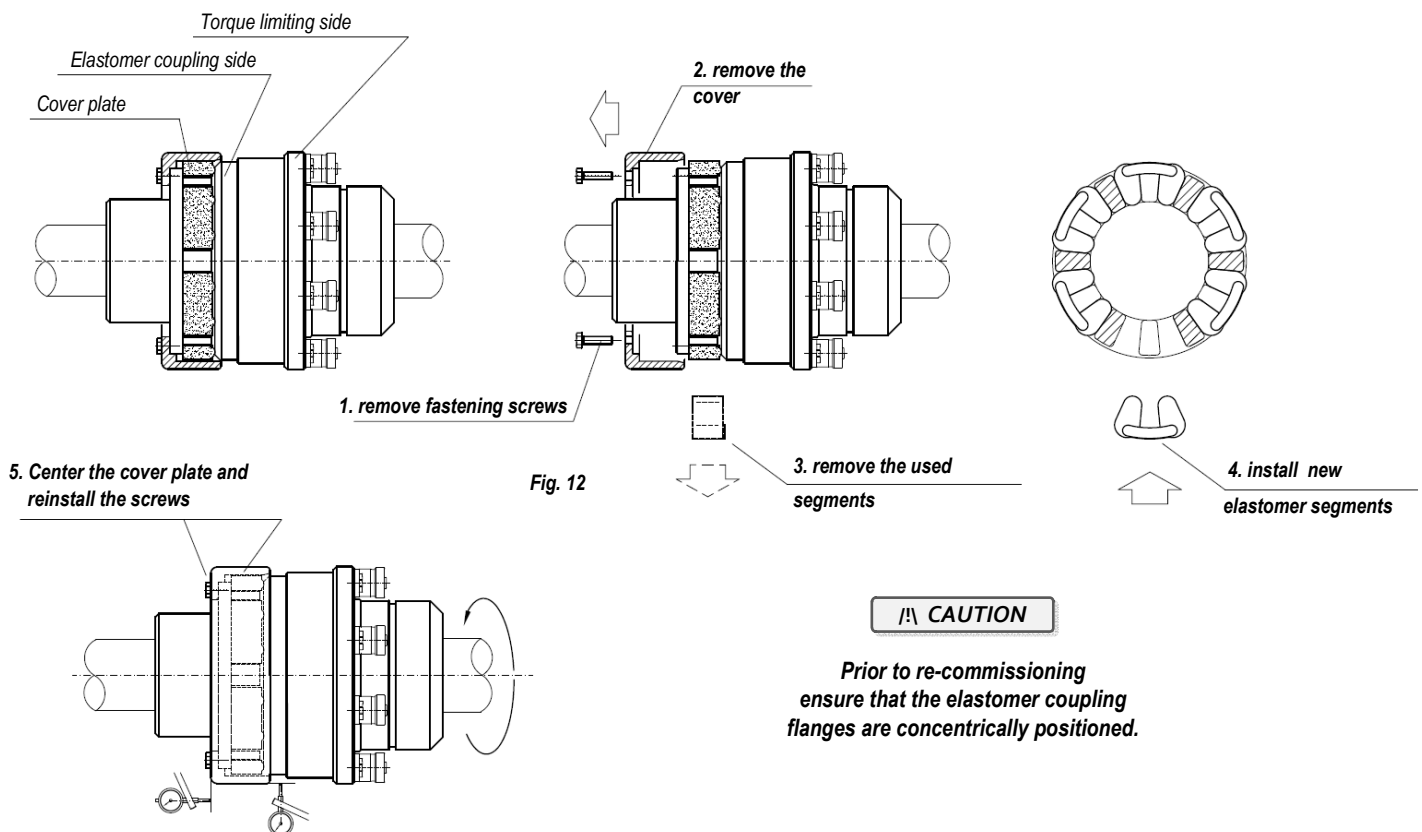

Fig. 11

A1.1 CHANGING THE ELASTOMER SEGMENTS – ST2 Series :



INSTRUCTION MANUAL

ST SAFETY COUPLINGS



ST / Rev. 17.12

STE

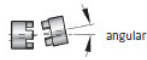

A2.0 ELASTOMER SEGMENTS – STE Series :

The equalizing element of the STE safety coupling is the elastomer insert. It transmits torque without backlash or vibration. There are 5x Elastomer segments built in the safety coupling.

The elastomer insert defines the characteristics of the entire drive system. Backlash is eliminated by the press fit of the elastomer into the hubs. Through variation of the Shore hardness of the elastomer insert, the coupling system can be optimized for the ideal torsional characteristics.

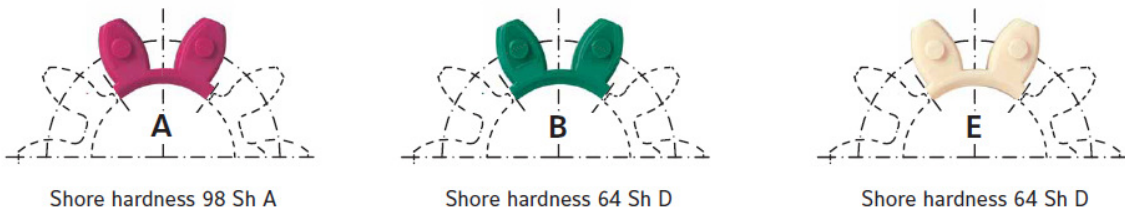

Fig. 13

Shore hardness 98 Sh A

Shore hardness 64 Sh D

Shore hardness 64 Sh D

DESCRIPTION OF THE ELASTOMER TYPES

Type	Shore hardness	Color	Material	Relative damping (μ)	Temperature range	Features
A	98 Sh A	red	TPU	0.4 - 0.5	-30°C to +100°C	high damping
B	64 Sh D	green	TPU	0.3 - 0.45	-30°C to +120°C	high torsional stiffness
E	64 Sh D	beige	Hytrel	0.3 - 0.45	-50°C to +150°C	temperature resistant

The values of relative damping were determined at 10 Hz and +20° C.

Tab. A2

A2.1 CHANGING THE ELASTOMER SEGMENTS – STE Series :

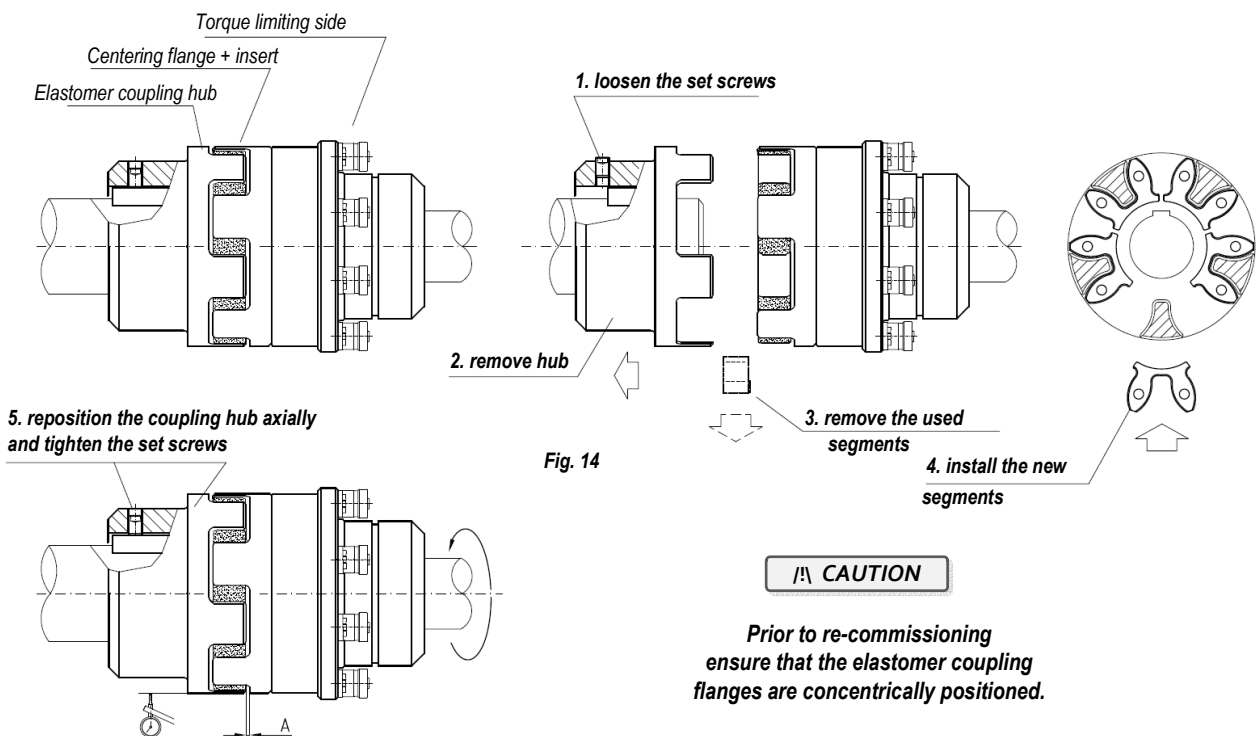

Fig. 14

CAUTION

Prior to re-commissioning ensure that the elastomer coupling flanges are concentrically positioned.

INSTRUCTION MANUAL

ST SAFETY COUPLINGS



ST / Rev. 17.12

STN

A3.0 INSTALLATION :

1. Ensure that the shaft is clean and free of nicks, burrs, rust, etc. Also ensure that all clamping bolts are present and loose prior to sliding the torque limiter onto the shaft.

Caution: If bolts are not loose during initial installation, permanent damage may occur.

2. Use a thin coating of machine oil to lightly lubricate the bore and shaft for ease of assembly.

Caution: Do not use lubricants containing Molybdenum Disulfide (MoS_2).

3. Before tightening clamping bolts, ensure that the conical clamping ring is parallel to the face of the torque limiter. Using a torque wrench, tighten bolts uniformly in circular sequence (not in a star pattern) to $1/3 (T_A)$ of installation torque value. Next, tighten each bolt to $2/3 (T_A)$ installation torque value in same manner. Finally, tighten bolts to full installation torque value (T_A).

4. Verify final installation torque value (T_A) of each clamping bolt with torque wrench. Installation is now complete.

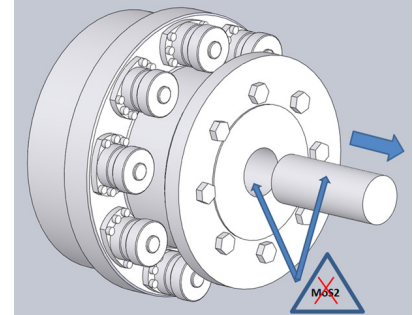

Fig. 15

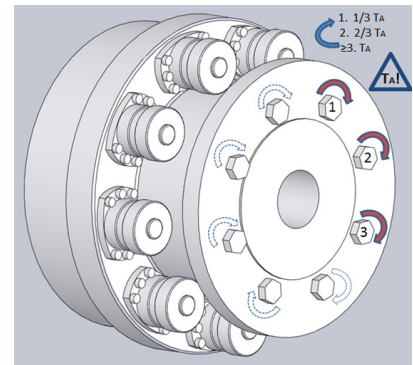

Fig. 16

A3.1 REMOVAL :

5. Loosen the clamping bolts evenly and in reverse circular sequence as shown in step 3. Failure to do so could result in jamming the conical clamping ring inside the torque limiter. **Caution:** Do not completely remove the clamping bolts from the threaded holes, as this can create a potential hazard.

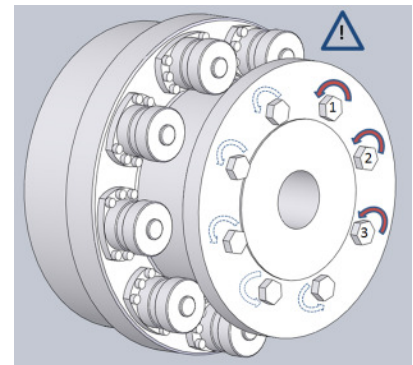

Fig. 17

6. After properly loosening all clamping bolts, ensure shaft is clean and free of nicks, burrs, rust, etc. and slide the torque limiter off the shaft.

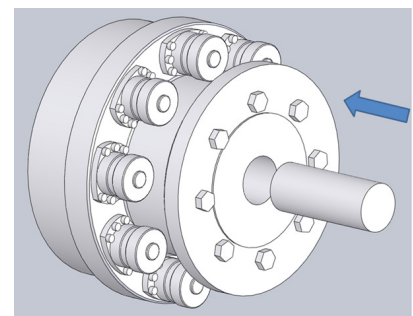

Fig. 18